

# HYVA CYLINDER

714 05 421



type: UMB 149-5-1480-K258-50-3/4"-HC

tipping weight: 12-23 ton

page # 1 / 2

Stage diameters 149 129 110 91 72	front view cylinder		<table border="1"> <tr><td>A</td><td>205</td></tr> <tr><td>ØC</td><td>170</td></tr> <tr><td>G<sup>1</sup></td><td>525</td></tr> <tr><td>I</td><td>267</td></tr> <tr><td>K<sup>1</sup></td><td>258</td></tr> <tr><td>M<sup>1</sup></td><td>99</td></tr> <tr><td>ØP</td><td>100</td></tr> <tr><td>ØQ</td><td>65</td></tr> <tr><td>S</td><td>280</td></tr> <tr><td>ØW</td><td>50</td></tr> <tr><td>X</td><td>45</td></tr> </table>	A	205	ØC	170	G <sup>1</sup>	525	I	267	K <sup>1</sup>	258	M <sup>1</sup>	99	ØP	100	ØQ	65	S	280	ØW	50	X	45
A	205																								
ØC	170																								
G <sup>1</sup>	525																								
I	267																								
K <sup>1</sup>	258																								
M <sup>1</sup>	99																								
ØP	100																								
ØQ	65																								
S	280																								
ØW	50																								
X	45																								

<sup>1</sup>including 20 mm pull-out [tol. -5; +30 mm]

<sup>2</sup>cylinder is delivered including oil inlet swivel adapter and cup

## specifications

total stroke <sup>1</sup>	1480 mm
dry weight cylinder only	69 kg
total volume	16.3 L
working volume	15.0 L
maximum pressure	220 bar
maximum pump flow	61 l/min
maximum allowable thrust first stage <sup>3</sup>	20.0 ton
oil inlet	3/4" BSP

## technical notes

This cylinder is a lifting device only and may not be used as a structural member or be subjected to side load. Sideload and/or poor alignment might result in cylinder leakage. Hyva therefore strongly recommends the use of a cradle, even in instances where the cylinder only tips to the rear or to the side. The cylinder is painted black RAL9005. For suitable hydraulic oils, please refer to data sheet OIL-0011. For details of available brackets and cradles, please refer data sheet 015BRA06.

Detailed calculations can be made using the HYVA Tipper Program, freely available from [tipper.hyva.com](http://tipper.hyva.com).

<sup>3</sup>The cylinder thrust on the first stage (from the HYVA Tipper Program) must not exceed the maximum allowable (see specifications above).

## tipping view

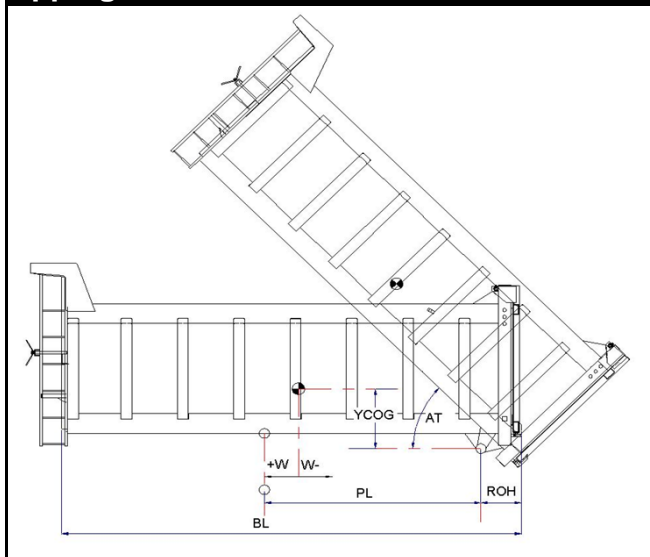

## tipping weight

PL	1930			mm	1710		
YCOG	600			mm	600		
ROH	600			mm	600		
BL	5620	5060	4600	mm	5130	4620	4200
CYL w.r.t. COG (W)	-280	0	230	mm	-260	0	210
	Tipping weight for full stroke of 46°				Tipping weight for full stroke of 52°		
Tipping weight	12	14	17	ton	13	16	19
	Tipping weight for second last stage, up to 37°				Tipping weight for 2nd last stage, up to 42°		
Tipping weight	16	20	23	ton	17	20	23

# HYVA CYLINDER

714 05 421

type

UMB 149-5-1480-K258-50-3/4"-HC

page # 2 / 2

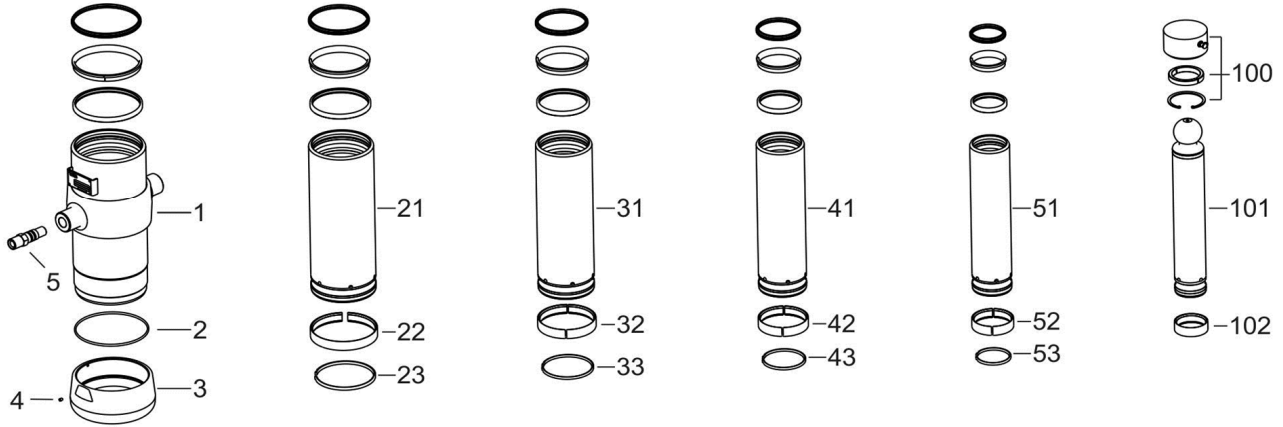

## Spare part list

Pos	Part no.	Description	Qty.
1	73506300	BASE 169-0398-N0159	1
2	01226709	O-RING 165 X 4 NBR 70 SHORE	1
3	73101040	THREADED BOTTOM UM 169	1
4	01792571	LOCKING SCREW M6X12 INT. HEX. DIN 916	1
5	73103002	OIL INLET ADAPTOR UM 3/4"OT+O-RING	1
21	73605301	STAGE 149-0398-HC	1
22	71807149 K	SLIDER FL 149	1
23	71812149 K	LIFTRING FL 149/HP 150	1
31	73604301	STAGE 129-0398-HC	1
32	71807129 K	SLIDER FL 129/GF 129 (2 X 1/2)	1
33	71812129 K	LIFTRING FL 129/HP 129	1
41	73603301	STAGE 110-0398-HC	1
42	71807110 K	SLIDER FL 110/GF 110 (2 X 1/2)	1
43	71812110 K	LIFTRING FL 110	1
51	73602301	STAGE 091-0398-HC	1
52	71807091 K	SLIDER FL 091 (2 X 1/2)	1
53	71812091 K	LIFTRING FL 091	1

## Spare part list

Pos	Part no.	Description	Qty.
100	01745102	RETAINER KIT UMB D.65	1
101	73401301	PISTON B 072-0438-HC	1
102	71807072 K	SLIDER FL 072 (2 X 1/2)	1

## Seal kit complete

Part no.	Description
719 04 550K	Complete packset: Consists of all packsets with packset grease and o-ring.