

REPAIR INSTRUCTIONS

GEAR PUMPS BRITE SERIES

REPLACING THE INNER SHAFT SEALS (35L UP TO 82L)

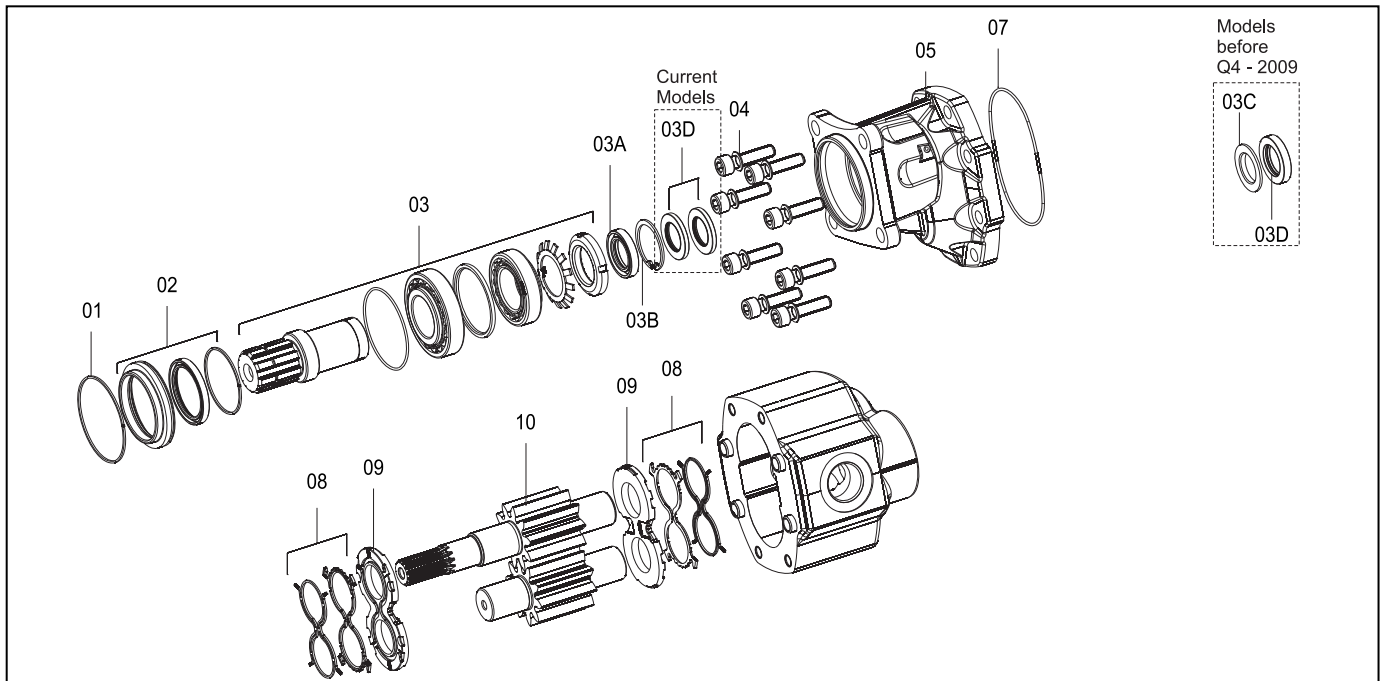

The steps

- Clamp the pump in a vice, shaft pointing up.
 - Remove the circlip (01) with a small screwdriver.
 - Use a slide hammer to take the shaft, bearings (03) and shaft seal (02) out.
 - Unscrew the 8 Allen bolts (04) around the pump housing.
 - Carefully remove the front half of the pump (05). It may need a bit of hammering with a plastic hammer to loosen it.
 - Now remove with a small screwdriver the upper shaft seal (3A). Take notice of its colour (brown).
 - Remove the circlip (3B) with a pair of needle-nosed pliers.
 - Remove the back-up washer (3C), only for models before Q4 2009.
 - Remove the shaft seal (3D) or 2 shaft seals for current models.
-
- Put some clean grease into the seal seat.
 - Insert the 2 shaft seals (3D). Open side to the back!
 - Put some grease Polymer 400 in the circlip groove.
 - Mount the circlip (3B) and also grease it with Polymer 400.
 - Insert the shaft seal (3A) with open side to the front.
 - Use a piece of pipe $\varnothing 40 \times \varnothing 34$ (free of burs or sharp edges) to carefully tap this shaft seal in its seat.
 - Now cover the end of the splines shaft (10) with a few rounds of plastic tape.
 - Mount the o-ring (07) in the groove of the front half. Use a few dots of grease to keep it in position.
 - Grease the female splines of the front shaft with Rocol molypaste.

- Carefully place the front cover (05) back. Tap it in position on the centring bushes.
- Mount the 8 Allen bolts (04). Torque them up to 70 Nm.
- Remove the tape from the shaft.
- Fill the opening for the bearings with 30-35 grams of grease. Mobil SHC100. Also lightly oil the outside of the bearings.
- Place the shaft and bearings (03) in position. Use a piece of pipe of the diameter of the outer ring of the bearing to tap the unit over the splines.
- Try to rotate the shaft. If that goes well, tap the pipe until the bearing is in place.
- Mount the shaft seal ring with o-ring (02). Lightly grease it before mounting with Polymer grease.
- Mount the circlip (01).

Hyva Sealkit:

Partno.: 024.60.000, c/w Mobil SHC100, Polymer and Rocol Molypaste grease.

Required tools:

Plastic hammer - Small screwdriver - Allen key size 8 mm - Torque wrench (min. 70 Nm) – pair of needle nosed pliers - Slide hammer with M10 thread - Piece of pipe $\varnothing 40$ - Plastic tape - Hydraulic oil.

NOTE: Shaft seal (03D) has been replaced by 2 smaller shaft seals and the backup washer is removed, Q4-2009.

REPAIR INSTRUCTIONS

GEAR PUMPS BRITE SERIES

REPLACING PRESSURE PLATES, CHECKING FOR WEAR (35L UP TO 82L)

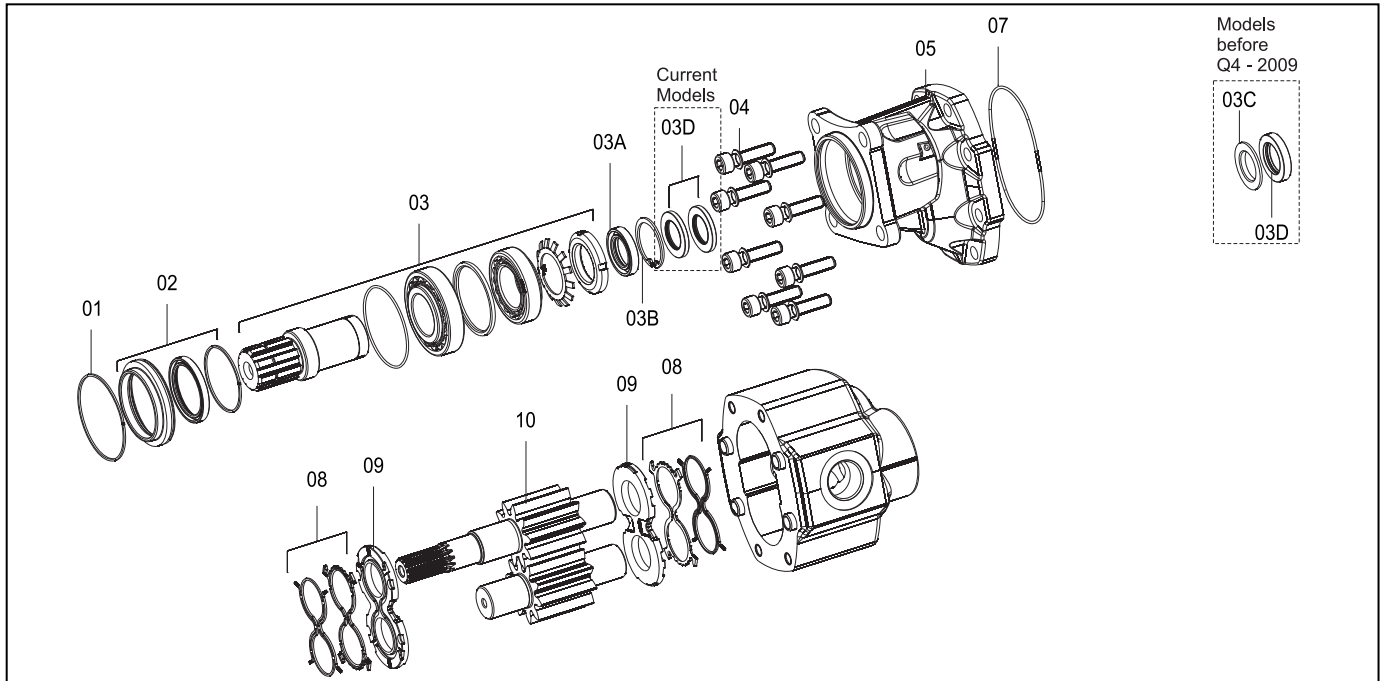

The steps

- Clamp the pump in a vice, shaft pointing up.
- Remove the circlip (01) with a small screwdriver.
- Use a slide hammer to take the shaft and bearings (03) and shaft seal (02) out.
- Unscrew the 8 Allen bolts (04) around the pump housing.
- Carefully remove the front cover of the pump (05). It may need a bit of hammering with a plastic hammer to loosen it. Pay attention not to damage the shaft seals and not to loose the o-ring (07).
- Mark the position of the pressure plate with a "permanent marker"
- Remove the pressure plate (09) and seals (08)
- Remove the gearwheels.
- Remove the other pressure plate and seal.
- Check the pressure plates for scratches, excessive wear and ovality of the holes.
- If required, mount new plates.
- Check the inside of the pump for scratches or extreme wear.
- Check the bearing bushes for the gearwheels on extreme wear.
- Check the gearwheels on pitting, blueing or extreme wear.
- If you find any of these signs, it is probably not worth repairing the pump.
- Mount new seal rings and backup rings (08) on the pressure plates (09).
- Lightly oil the plates and gearwheels
- Mount pressure plates and gearwheels in the same position as before.
- Now cover the end of the splines shaft (10) with a few rounds of plastic tape.

- Grease the female splines of the front shaft with Rocol molypaste.
- Mount the o-ring (07) in the groove of the front cover. Use a few dots of grease to keep it in position.
- Carefully place the front cover (05) back. Tap it in position on the centring bushes.
- Mount the 8 Allen bolts (04). Torque them up to 70 Nm.
- Remove the tape from the shaft.
- Fill the opening for the bearings with 30-35 grams of grease. Mobil SHC10. Also lightly oil the outside of the bearings.
- Place the shaft and bearings (03) in position. Use a piece of pipe of the diameter of the outer ring of the bearing to tap the unit over the splines.
- Try to rotate the shaft. If that goes well, tap the pipe until the bearing is in place.
- Mount the shaft seal with o-ring (02). Lightly grease it before mounting with Polymer grease.
- Mount the circlip (01).

Hyva Sealkit:

Partno.: 024.60.000, c/w Mobil SHC100, Polymer and Rocol Molypaste grease.

Required tools:

Plastic hammer - Small screwdriver - Allen key size 8 mm - Torque wrench (min. 70 Nm)
Slide hammer with M10 thread - Piece of pipe Ø 70 - Plastic tape - Hydraulic oil.

NOTE: Shaft seal (03D) has been replaced by 2 smaller shaft seals and the backup washer is removed, Q4-2009.